

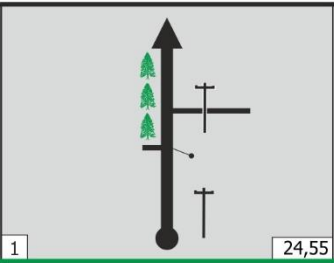



Data: 07.08.2024 **Czas:** 19:30
Temat: KOMUNIKAT NR 3 **Dok. Nr:** 1.3
Od: Dyrektora Zawodów
Do: Wszystkich zawodników – członków załóg
Liczba stron: 9

1. AMENDMENTS TO THE ROAD BOOK / ZMIANY W KSIĄŻCE DROGOWEJ

Page 63, box 1-3

0,00	---		    <p>NEW</p> <p>41,43</p> <p>N-49° 56.860' E-21° 57.167'</p>
0,42	0,42		<p>DNC 0</p> <p>NEW BOX</p> <p>NEW</p> <p>41,01</p>
0,46	0,04		<p>DNC 1</p> <p>DNC 2</p> <p>2023</p> <p>40,97</p>

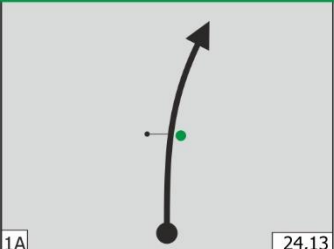
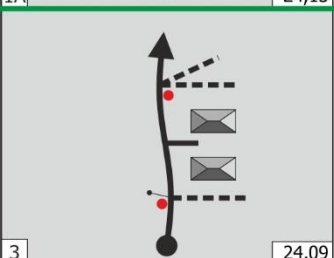
Page 64, box 9-10

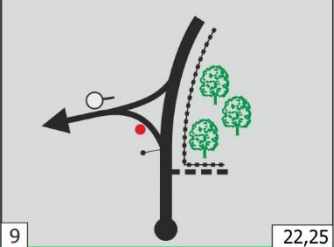
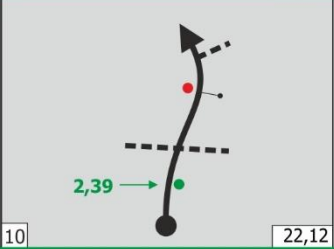
2,30	0,40		DNC 13	2023	
		9	22,25	39,13	
2,43	0,13		DNC 13A DNC 14	BOX MODIF.	NEW
		10	22,12	39,00	

Page 65, box 12-13

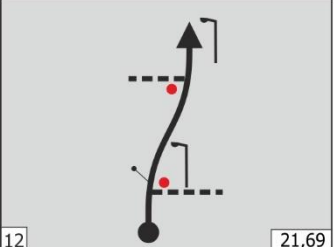
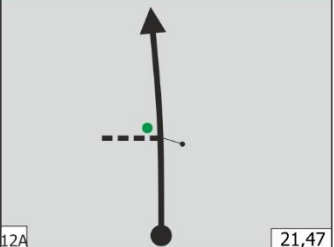
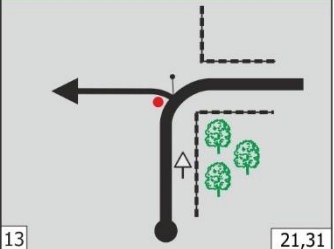
2,86	0,22		DNC 16 DNC 17	2023	
		12	21,69	38,57	
3,08	0,22		DNC 17A	NEW BOX	NEW
		12A	21,47	38,35	
3,24	0,16		DNC 18	2023	
		13	21,31	38,19	
			N-49° 55.593'	E-21° 57.611'	

Page 67-68, box 25-26

6,49	0,20		DNC 34	2021	34,94	
6,72	0,23		DNC 34A DNC 34B	NEW BOX	NEW	34,71
6,91	0,19		DNC 34C DNC 34D	NEW BOX	NEW	34,52
7,10	0,19		DNC 34E	NEW BOX	NEW	34,33
7,15	0,05		DNC 35		2021	34,28

Page 68, box 26-27

7,15	0,05		DNC 35	2021	34,28	
7,50	0,35		DNC 35A	NEW BOX	NEW	33,93
7,66	0,16		DNC 35B DNC 35C	NEW BOX	NEW	33,77
7,75	0,09		DNC 36	 	2021	33,68



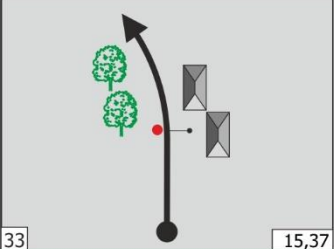
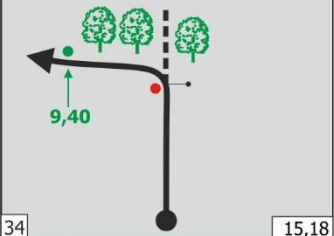

Page 69, box 33-34

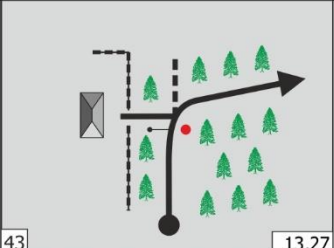
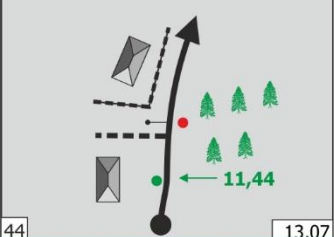
9,18	0,13		DNC 45	NEW	32,25	
9,37	0,19		DNC 46 DNC 46A	BOX MODIF.	NEW	32,06

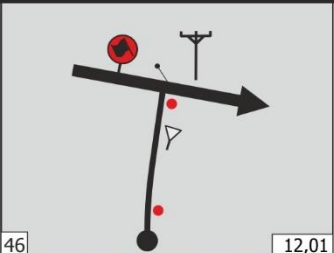

Page 71, box 43-44

11,28	0,15		DNC 59	NEW	30,15	
11,48	0,20		DNC 59A DNC 60	BOX MODIF.	NEW	29,95

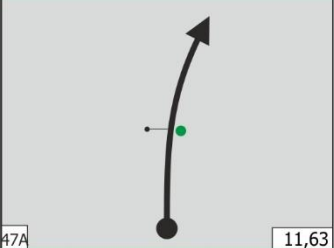
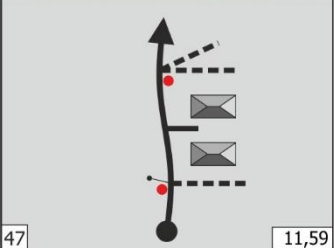

Page 72, box 46-47

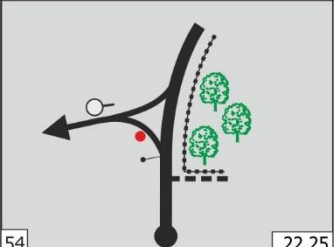
12,54	0,36		 R-S   DNC 67 DNC 68 N-49° 55.844' E-21° 57.209'	2023 28,89
12,92	0,38		DNC 0 NEW BOX	NEW 28,51
12,96	0,04		DNC 1 DNC 2	2023 28,47

Page 73 , box 54-55

14,80	0,40		DNC 13 	2023 26,63
14,93	0,13		DNC 13A DNC 14 BOX MODIF.	NEW 26,50

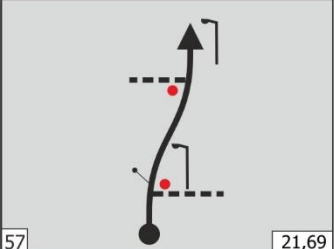
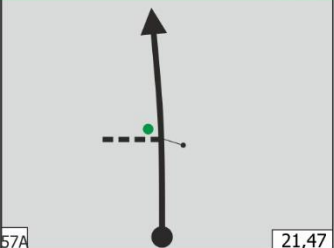
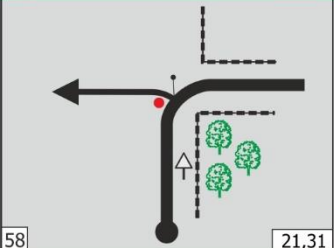

Page 74, box 57-58

15,36	0,22		DNC 16 DNC 17	2023	26,07	
15,58	0,22		DNC 17A	NEW BOX	NEW	25,85
15,74	0,16		 R-1  DNC 18	2023	25,69	
		N-49° 55,593' E-21° 57,611'				

Page 76-77, box 70-71

18,99	0,20		DNC 34	2021	22,44	
19,22	0,23		DNC 34A DNC 34B	NEW BOX	NEW	22,21
19,41	0,19		DNC 34C DNC 34D	NEW BOX	NEW	22,02
19,60	0,19		DNC 34E	NEW BOX	NEW	21,83
19,65	0,05		DNC 35		2021	21,78

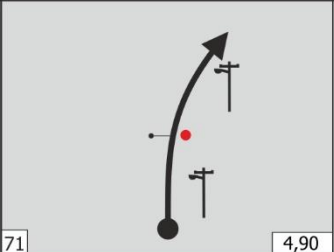
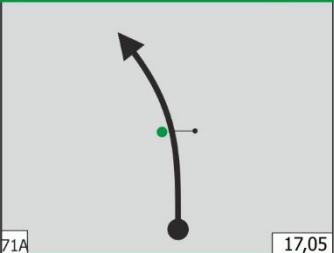
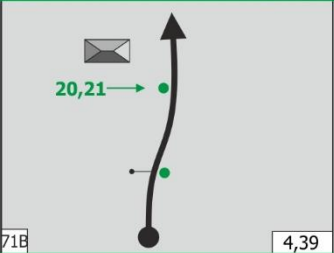
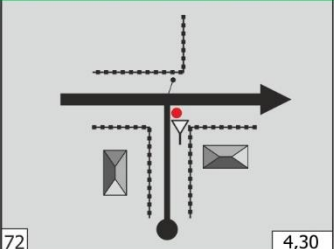
Page 77, box 71-72

19,65	0,05		DNC 35	2021	21,78	
20,00	0,35		DNC 35A	NEW BOX	NEW	21,43
20,16	0,16		DNC 35B DNC 35C	NEW BOX	NEW	21,27
20,25	0,09		DNC 36	 	2021	21,18

Łukasz Biegus
Clerk of the Course
Dyrektor Rajdu